

## Measuring current transformers of the WS... series

### Measuring current transformers of the WS...-8000 series

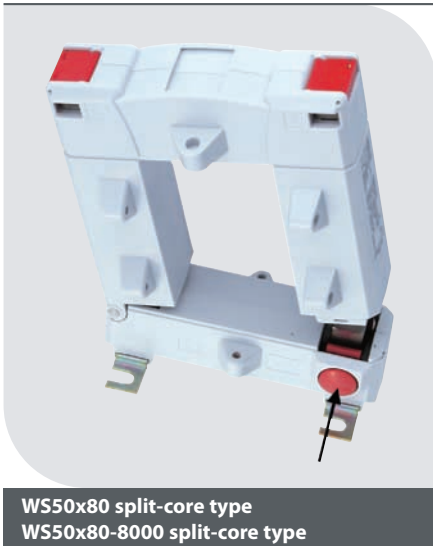

Measuring current transformer WS50x80  
Measuring current transformer WS50x80-8000



WS50x80 split-core type  
WS50x80-8000 split-core type

#### Device features

##### Measuring current transformer WS...

- for residual current monitoring systems of the RCMS460 / 490 series
- for residual current monitors of the RCM420, RCM460 and RCM470 series
- for insulation fault location systems of the EDS460 / 490 series

##### Measuring current transformer WS...-8000

- for insulation fault evaluators of the EDS473(E)-12, EDS474(E)-12, EDS461 and EDS491 series

#### Approvals



#### Product description

Split-core type measuring current transformers of the WS... and WS...-8000 series can be opened using the interlock knob to enclose the conductors to be monitored. That allows easy retrofitting in existing installations.

Measuring current transformers of the WS... and WS...-8000 are highly sensitive measuring current transformers of split-core type which in combination with residual current monitors and evaluators of the RCM and RCMS series convert AC currents into evaluable measurement signals.

In addition, the measuring current transformers are suitable for use in combination with insulation fault location systems (EDS). The CTs measure the test current generated by a PGH insulation fault test device or an A-ISOMETER® IRDH. In combination with insulation fault evaluators of the EDS series, the test current is converted into evaluable signals.

Connection to the respective devices is via a two-wire cable.

#### Installation instructions

- Make sure that all live conductors are routed through the measuring current transformer.
- Do not route shielded conductors through the measuring current transformer.
- Never route a PE conductor through the measuring current transformer!

#### Wiring diagram

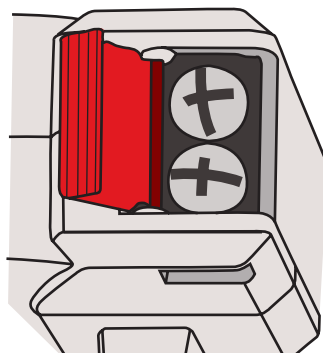
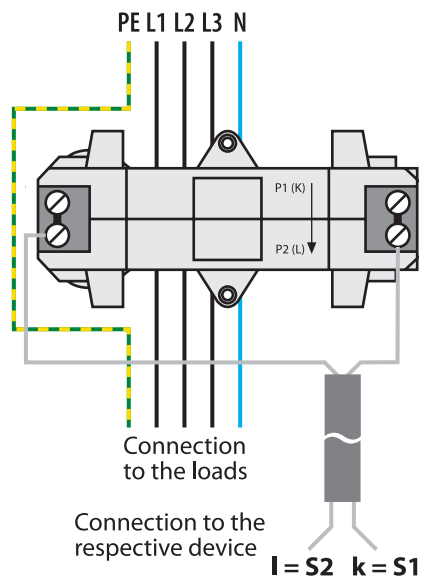

#### Measuring current transformer WS...

Connection to the respective residual current monitoring system of the RCMS series, residual current monitors of the RCM series or insulation fault location system of the EDS series.

#### Measuring current transformer WS...-8000

Connection to the respective insulation fault evaluators EDS473(E)-12, EDS474(E)-12, EDS461 and EDS491.

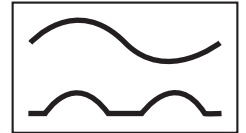

### Technical data

#### Insulation coordination acc. to IEC 60664-1 / IEC 60664-3

Rated insulation voltage	800 V
Rated impulse voltage / pollution degree	8 kV / III

#### CT circuit WS...

Rated primary residual current	30 mA...10 A
Rated secondary residual current	0.0167 A
Rated transformation ratio $K_N$	10 / 0.0167 A
Rated burden	max. 180 $\Omega^*$
Nominal power	0.05 VA
Frequency range	42 Hz...3 kHz
Rated continuous thermal current $I_{cth}$	40 A
Rated short-time thermal current $I_{tth}$	60 x $I_{cth}$ = 2.4 kA / 1 s
Rated dynamic current $I_{dyn}$	2.5 x $I_{tth}$ = 6.0 kA / 40 ms

#### CT circuit WS...-8000

Rated primary residual current	30 mA...1 A
Rated secondary residual current	0.000125 A
Rated transformation ratio $K_N$	10 / 0.000125 A
Rated burden	2400 $\Omega$
Nominal power	0.0375 VA
Frequency range	42 Hz...3 kHz
Rated continuous thermal current $I_{cth}$	6 A
Rated short-time thermal current $I_{tth}$	60 x $I_{cth}$ = 0.36 kA / 1 s
Rated dynamic current $I_{dyn}$	2.5 x $I_{tth}$ = 0.9 kA / 40 ms

#### Environmental conditions

Operating temperature	-25 °C...+70 °C
Climatic class acc. to IEC 60721	
Stationary use (IEC 60721-3-3)	3K5 (except condensation and formation of ice)
Transport (IEC 60721-3-2)	2K5 (except condensation and formation of ice)
Long-time storage (IEC 60721-3-1)	1K5 (except condensation and formation of ice)
Classification of mechanical conditions IEC 60721	
Stationary use (IEC 60721-3-3)	3M4
Transport (IEC 60721-3-2)	2M2
Long-time storage (IEC 60721-3-1)	1M3

#### Connection

Type of connection	screw terminals
rigid / flexible / conductor sizes	0.08...2.5 / 0.08...2.5 mm <sup>2</sup> / 28...12 AWG
Stripping length	8...9 mm

#### Connection EDS, RCM(S) measuring current transformers

Single wire $\geq 0.75$ mm <sup>2</sup>	0...1 m
Single wire, twisted $\geq 0.75$ mm <sup>2</sup>	0...10 m
Shielded cable $\geq 0.5$ mm <sup>2</sup>	0...40 m

Recommended cable	
(shielded, shield on one side connected to line conductor, not connected to PE)	J-Y(ST)Y min. 2 x 0.8

#### Other

Degree of protection, internal components (IEC 60529)	IP40
Degree of protection, terminals (IEC 60529)	IP20
Screw mounting	M5 with mounting brackets
Flammability class	UL94V-0
Standards	IEC 60044-1
Instruction leaflet WS...	BP409015
Instruction leaflet WS...-8000	BP108018
Approval	UL under consideration, GOST

\* The rated burden may vary depending on the respective device data sheet.

### Ordering information

Type	Inside dimensions	Fixing Mounting bracket	Art. No.
WS20x30	20 x 30 mm	×	B 9808 0601
WS50x80	50 x 80 mm	×	B 9808 0603
WS80x120	80 x 120 mm	×	B 9808 0606
WS20x30-8000*	20 x 30 mm	×	B 9808 0602
WS50x80-8000*	50 x 80 mm	×	B 9808 0604

### Dimension diagram

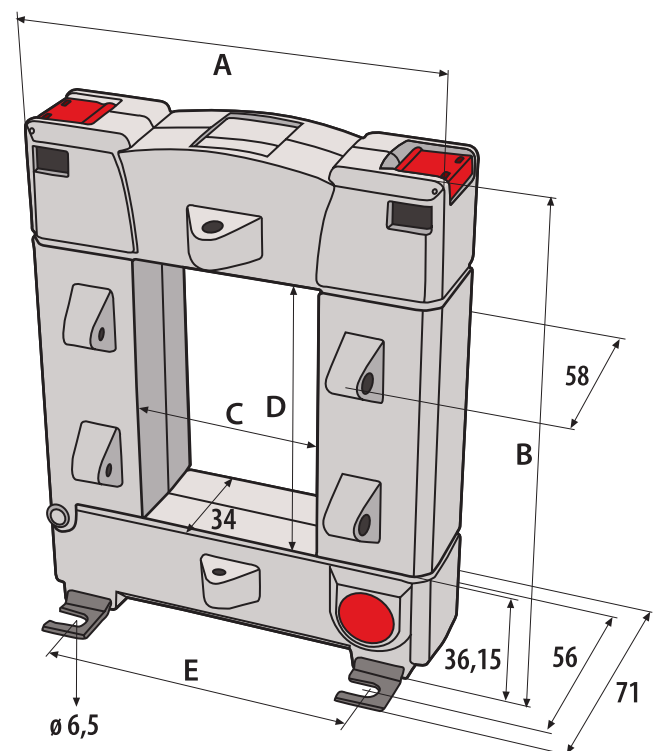

### Dimensions

Type	A	B	C	D	E	Weight
WS20x30	93	106.15	23	33	64	0.6 kg
WS50x80	125	158.15	55	85	96	1.04 kg
WS80x120	155	198.15	85	125	126	1.4 kg
WS20x30-8000*	93	106.15	23	33	64	0.63 kg
WS50x80-8000*	125	158.15	55	85	96	1.08 kg

Dimensions in mm

### Selection list

Type	RCM420	RCM470	RCMS460	RCMS470	EDS460	EDS461	EDS470	EDS473	EDS474
			RCMS490		EDS490	EDS491			
WS20x30	×	×	×	×	×	--	×	--	--
WS50x80	×	×	×	×	×	--	×	--	--
WS20x30-8000*	--	--	--	--	--	×	--	×	×
WS50x80-8000*	--	--	--	--	--	×	--	×	×

\* For insulation fault location systems of the EDS461 / 491 and EDS473 / 474 series.