

Residual current monitor RCMA423

AC / DC sensitive residual current monitor
for TN and TT systems
(AC, DC and pulsating DC currents)



RCMA423

Device features

- AC / DC sensitive residual current monitor Type B according to IEC 62020 and IEC 60755
- r.m.s. value measurement (AC + DC)
- Two separately adjustable response values 30 mA...3 A
- Frequency range 0...2000 Hz
- Start-up delay, response delay and delay on release
- Digital measured value display via LC display
- Measured value memory for operating value
- CT connection monitoring
- Power On LED, LED Alarm 1, LED Alarm 2
- Internal / external test / reset button
- Two separate alarm relays (one changeover contact each)
- N / O or N / C operation and fault memory behaviour selectable
- Continuous self monitoring
- Multi-functional LC display
- Password protection for device settings
- Sealable transparent cover
- Push-wire terminal (two terminals per connection)
- Two-module enclosure (36 mm)

Product description

The AC / DC sensitive residual current monitor RCMA423 is designed for monitoring earthed power supply systems (TN and TT systems) where smooth DC fault currents or residual currents continuously greater than zero may occur. These are in particular loads containing six-pulse rectifiers or two-pulse rectifiers with smoothing, such as converters, battery chargers, construction site equipment with frequency-controlled drives. Currents in single conductors can also be monitored by RCMA423.

The prewarning stage (50...100 % of the set response value $I_{\Delta n2}$) allows to distinguish between prewarning and alarm. Since the values are measured with measuring current transformers, the device is nearly independent of the load current and the nominal voltage of the system.

Applications

- AC / DC sensitive residual current monitoring in earthed two, three or four conductor systems (TN and TT systems)
- Monitoring of variable-speed drives, UPS systems, construction site equipment, printing machines, battery systems, laboratory equipment, wood working machines, MF welding systems, furniture industry, medical electrical equipment, etc.
- AC / DC sensitive current monitoring of single conductors de-energised under normal conditions (e. g. N and PE conductors)

Function

Once the supply voltage U_S is applied, the start-up delay is activated. Measured values changing during this time do not influence the switching state of the alarm relays.

Residual current measurement takes place via an external W20AB...W210AB series measuring current transformer. The currently measured value is shown on the LC display. In this way any changes, for example when circuits are connected to the system, can be recognised easily. If the measured value exceeds the set response values, the response delays " $t_{on1/2}$ " begin. Once the response delay " $t_{on1/2}$ " has elapsed, the "K1 / K2" alarm relays switch and the alarm LEDs "AL1 / AL2" light up. If the current falls below the release value (response value plus hysteresis), the release delay " t_{off} " begins. When " t_{off} " has elapsed, the alarm relays return to their initial position and the alarm LEDs AL1 / AL2 go out. If the fault memory is activated, the alarm relays remain in the alarm state and the LEDs light until the reset button is pressed or until the supply voltage is interrupted. The device function can be tested using the test button. Parameters are assigned to the device via the LCD and the control keys on the front of the device and can be password-protected.

Connection monitoring

The function of the device and the CT connections are continuously monitored. In the event of a fault, the alarm relays K1 / K2 switch without delay, the alarm LEDs AL1 / AL2 / ON flash. On removal of the fault, the alarm relays return to their initial position either automatically or by pressing the reset button.

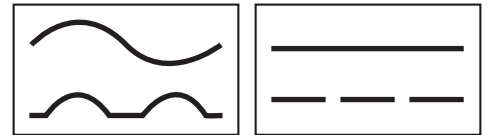

Operating and display elements

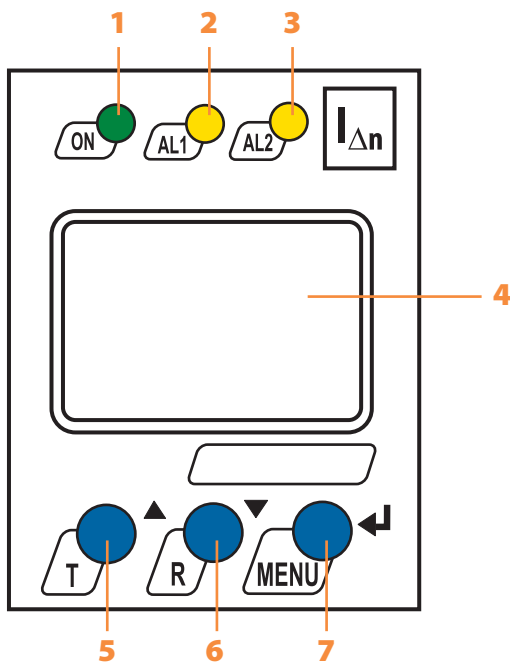

- 1 - Power On LED "ON" (green); lights when supply voltage is applied and flashes in the event of system fault alarm respectively in the event of CT malfunction
- 2 - Alarm LED "AL1" (yellow), prewarning; lights when the set response value $I_{\Delta n1}$ is exceeded or flashes in the event of system fault alarm respectively in the event of CT malfunction
- 3 - Alarm LED "AL2" (yellow), alarm; lights when the set response value $I_{\Delta n2}$ is exceeded or flashes in the event of system fault alarm respectively in the event of CT malfunction
- 4 - Multi-functional LC display
- 5 - Test button "T": start self test
Up key: change parameters, move upwards in the menu
- 6 - Reset button "R": delete saved alarms
Down key: change parameters, move downwards in the menu
- 7 - "MENU" key: call menu system
Enter key: confirm parameter change
ESC key: press the key > 1.5 seconds

Wiring diagram

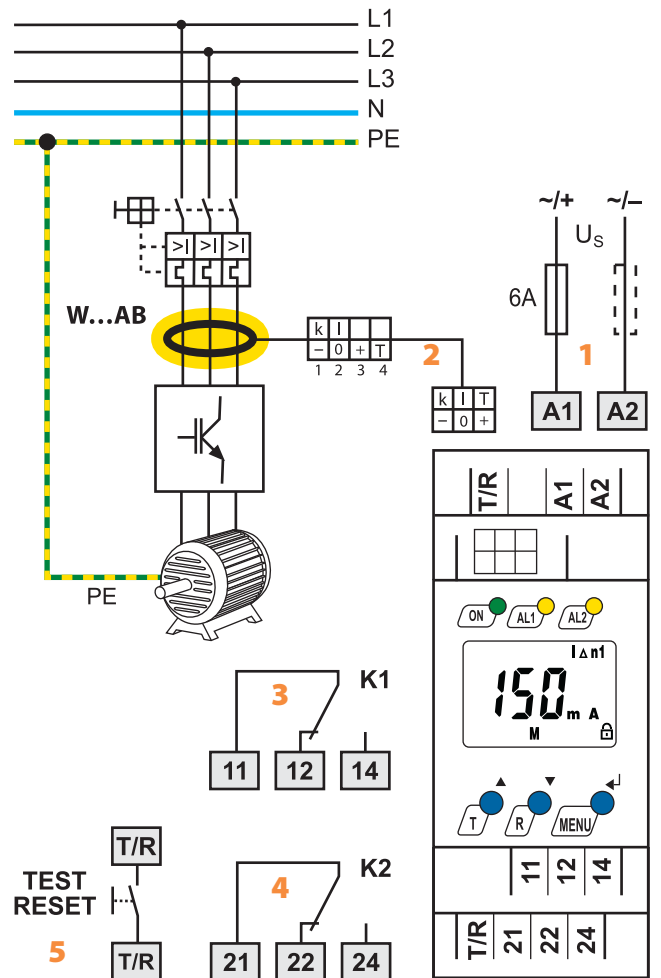

- 1 - Supply voltage U_S see ordering information (6 A fuse (recommended))
- 2 - Connector for the external W20AB...W210AB series measuring current transformer
- 3 - Alarm relay K1: $I_{\Delta n1}$ (prewarning)
- 4 - Alarm relay K2: Alarm $I_{\Delta n2}$ (alarm)
- 5 - Combined test and reset button "T / R"
short-time pressing (< 1.5 s) = RESET
long-time pressing (> 1.5 s) = TEST

Do not route the PE conductor through the measuring current transformer!

4.2

Connection of measuring current transformers

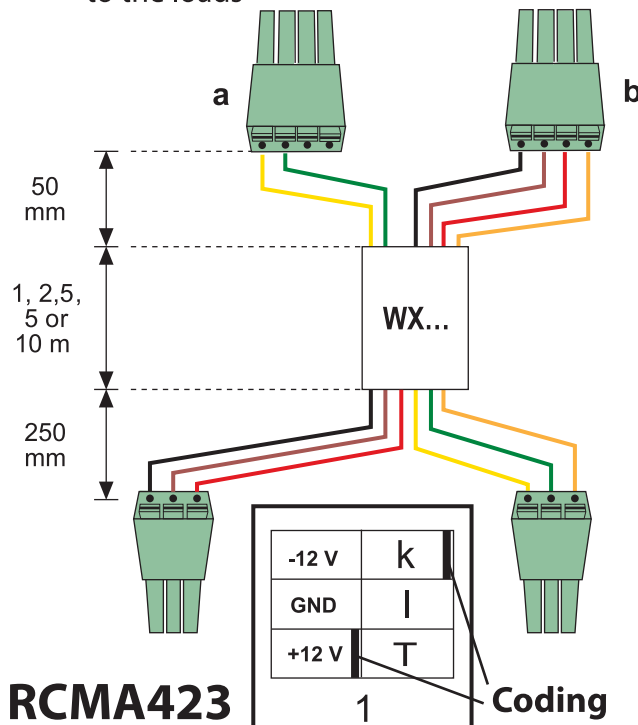
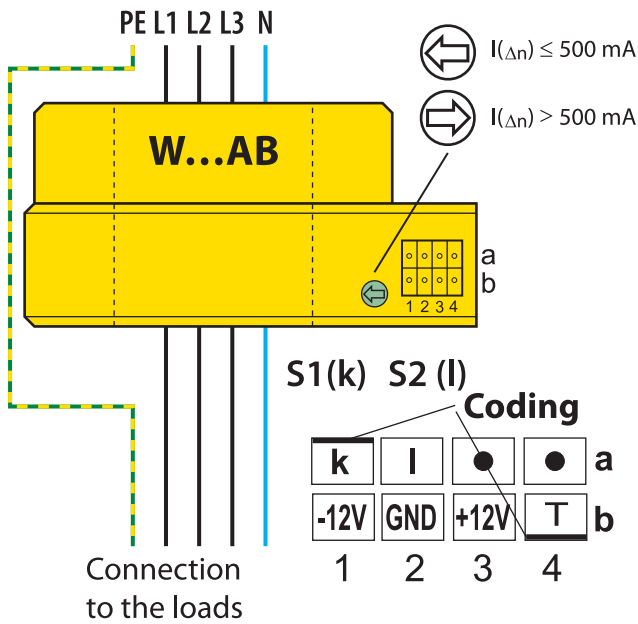

Connection to the RCMA423 residual current monitor using the WX-... connecting cable.

Colour coding for WX...: k = yellow, I = green, -12 V = black, GND = brown, +12 V = red, test (T) = orange

Dimension diagram XM420

Dimensions in mm

Open the front plate cover in direction of arrow!

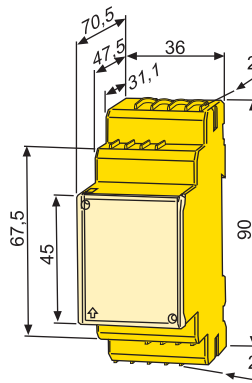

Screw fixing

Note: The upper mounting clip must be ordered separately (see "Accessories").

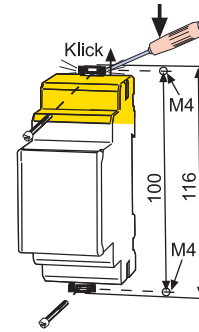

Residual operating current ranges of the different measuring current transformers	
Residual operating current ranges	Art. No.
30 mA...500 mA	W20AB
30 mA...3 A	W35AB; W60AB; W120AB
300 mA...3 A	W210AB

Technical data

Insulation coordination acc. to IEC 60664-1 / IEC 60664-3

Rated insulation voltage	250 V
Rated impulse voltage / pollution degree	2.5 kV / III
Protective separation (reinforced insulation) between (A1, A2) - (k / l / - / 0 / +, T / R) - (11, 12, 14) - (21, 22, 24)	
Voltage test according to IEC 61010-1	2.21 kV

Supply voltage

Supply voltage U_S	see ordering information
Power consumption	≤ 6,5 VA

Measuring circuit

External measuring current transformer	W20AB, W35AB, W60AB, W120AB, W210AB
Rated insulation voltage (measuring current transformer)	800 V
Operating characteristic acc. to IEC 60755	Type B
Rated frequency	0...2000 Hz
Measuring range AC / DC	3 mA...6 A
Relative uncertainty from the measured value at $f \leq 2$ Hz or ≥ 16 Hz	0...-35 %
Relative uncertainty from the measured value at $f > 2$ Hz... < 16 Hz	-35 %...+100 %
Display accuracy, measured value	± 17 %

Response values

Rated residual operating current $I_{\Delta n1}$ (prewarning)	50...100 % of $I_{\Delta n2}$, min. 15 mA (15 mA)*
Rated residual operating current $I_{\Delta n2}$ (alarm)	30 mA...3 A (30 mA)*
Hysteresis	10...25 % (15 %)*

Specified time

Start-up delay t	0...10 s (0 s)*
Response delay t_{on2} (alarm)	0...10 s (0 s)*
Response delay t_{on1} (prewarning)	0...10 s (1 s)*
Delay on release t_{off}	0...99 s (1 s)*
Operating time t_{ae} at $I_{\Delta n} = 1 \times I_{\Delta n1} / 2 / I_{\Delta n} = 5 \times I_{\Delta n1} / 2$	≤ 180 ms / ≤ 30 ms
Response time t_{an}	$t_{an} = t_{ae} + t_{on1} / 2$
Recovery time t_b	≤ 300 ms

Displays, memory

Display range, measuring value	0...6 A
Operating uncertainty	0...-35 % / ± 2 digit
Measured-value memory for alarm value	data record measured values
Password	off / 0...999 (off)*
Fault memory behaviour	on / off (on)*

Inputs / outputs

Cable length for external test / reset button	0...10 m
---	----------

Cable lengths for measuring current transformers

Single wire 6 x 0.75 mm ²	0...10 m
Connection	connectors, WX... recommended

Switching elements

Number of switching elements	2 x 1 changeover contact				
Operating principle	N / C operation / N / O operation (N / C operation)*				
Electrical endurance, number of cycles	10.000				
Contact data acc. to IEC 60947-5-1					
Utilisation category	AC-13	AC-14	DC-12	DC-12	DC-12
Rated operational voltage	230 V	230 V	24 V	110 V	220 V
Rated operational current	5 A	3 A	1 A	0.2 A	0.1 A
Minimum contact rating	1 mA at AC / DC ≥ 10 V				

EMC

EMC	IEC 62020: 2003-11				
Operating temperature	-25 °C...+55 °C				
Climatic class acc. to IEC 60721					
Stationary use (IEC 60721-3-3)	3K5 (except condensation and formation of ice)				
Transport (IEC 60721-3-2)	2K3 (except condensation and formation of ice)				
Long-time storage (IEC 60721-3-1)	1K4 (except condensation and formation of ice)				
Classification of mechanical conditions IEC 60721					
Stationary use (IEC 60721-3-3)					3M4
Transport (IEC 60721-3-2)					2M2
Long-time storage (IEC 60721-3-1)					1M3

Connection

Connection type	push-wire terminals				
Connection properties rigid	0.2...2.5 mm ² / AWG 24-14				
flexible without ferrule	0.2...2.5 mm ² / AWG 24-14				
flexible with ferrule	0.2...1.5 mm ² / AWG 24-16				
Stripping length	10 mm				
Opening force	50 N				
Test opening, diameter	2.1 mm				

Other

Operating mode	continuous operation				
Mounting	display-oriented				
Degree of protection, internal components / terminal (DIN EN 60529)	IP 30 / IP 20				
Enclosure material	polycarbonate				
Flammability class	UL94V-0				
DIN rail mounting acc. to	IEC 60715				
Screw mounting	2 x M4 with mounting clip				
Software version	D330 V1.0x				
Product standards	DIN EN 62020 (VDE 0663): 2005-11, IEC 62020: 2003-11				
Operating manual	TGH 1442				
Weight	≤ 150 g				

() * factory setting

Ordering information				
Type	Response range $I_{\Delta n}$	Frequency range	Supply voltage U_S *	Art. No.
RCMA423-D-1	30 mA...3 A	0...2000 Hz	DC 9.6...94 V / AC 42...460 Hz 16...72 V	B 7404 3023
RCMA423-D-2	30 mA...3 A	0...2000 Hz	DC 70...300 V / AC 42...460 Hz / 70...300 V	B 7404 3025

Device version with screw terminals on request. * absolute values

Measuring current transformers		
Type	Inside diameter (mm)	Art. No.
W20AB	∅ 20	B 9808 0008
W35AB	∅ 35	B 9808 0016
W60AB	∅ 60	B 9808 0026
W120AB	∅ 120	B 9808 0041
W210AB	∅ 210	B 9808 0040

Connection cable measuring current transformer – RCMA423-D		
Type	Length / m	Art. No.
WX-100	1	B 9808 0503
WX-250	2.5	B 9808 0504
WX-500	5	B 9808 0505
WX-1000	10	B 9808 0511

Accessories	
Type	Art. No.
Mounting clip for XM420 enclosure	B 9806 0008
Snap-on mounting W20..., W35...	B 9808 0501
Snap-on mounting W60...	B 9808 0502
(1 unit required for each device)	