

## A-ISOMETER® IRDH375

Insulation monitoring device for unearthed  
AC, AC/DC and DC systems (IT systems)



A-ISOMETER® IRDH375

### Device features

- Insulation monitoring for unearthed systems AC, AC/DC 0...793 V, DC 0...650 V
- Nominal voltage extendable via coupling device
- Two separately adjustable response values 1 k $\Omega$ ...10 M $\Omega$
- **AMP<sup>Plus</sup>** measuring principle
- Automatic adaptation to the system leakage capacitance
- Info key to display device settings and the system leakage capacitance
- Continuous self monitoring, with automatic alarm message
- Automatic self test, selectable
- Connection for external k $\Omega$  indication
- Test and reset button
- Connection external test/reset button
- Two separate alarm relays with two voltage-free changeover contacts
- N/O or N/C operation
- Alarm relay for system fault (N/C operation)
- Backlit LC display
- RS-485 interface
- Plug-in terminals

### Approvals



### Product description

The A-ISOMETER® of the IRDH375(B) series is designed to monitor the insulation resistance of unearthed main circuits (IT systems) AC, AC/DC 0...793 V resp. DC 0...650 V. The **AMP<sup>Plus</sup>** measuring principle meets the particular requirements of modern power supplies which often include rectifiers, converters, thyristor-controlled DC drives and directly connected DC components. In these systems often high leakage capacitances against earth occur due to interference suppression measures. The IRDH375(B) automatically adapts itself to the existing system conditions.

In combination with a coupling device, the Isometers can also be used for higher voltages. An external supply voltage allows de-energized systems to be monitored too.

### Application

- AC, DC or AC/DC main circuits
- AC/DC main circuits with directly connected DC components, such as rectifiers, converters, and thyristor-controlled DC drives
- UPS systems, battery systems
- Heaters with phase control
- Systems including switched-mode power supplies
- IT systems including high leakage capacitances
- Coupled IT systems

### Function

When the insulation resistance between the system conductors and earth falls below the set response value, the alarm relays switch and the alarm LEDs light up. Two separately adjustable alarm relays allow to distinguish between prewarning and alarm. The measured value is indicated on the LC display or an externally connectable measuring instrument. In this way any changes, for example when circuits are connected to the system, can be recognized easily. The fault message can be stored. The fault memory can be reset by pressing the reset button. By pressing the test button, the function of the device as well as the connections to system and earth can be tested. Pressing the info key provides additional information, such as the existing system leakage capacitance or device settings.

The function of the device and the system and earth connections are continuously monitored. When a fault occurs, the system fault relay switches and the alarm LED "system fault" lights up. The parameterization of the device can be carried out via the LC display or the function keys integrated in the front plate.

### Device version IRDH375B

Device version IRDH375B includes the following additional functions:

- History memory with real-time clock to store all alarm messages with date and time stamp.
- Galvanically isolated RS-485 interface (BMS protocol) for data exchange with other BENDER devices
- Isometer disconnecting relays for the operation of several A-ISOMETER®s in coupled IT systems
- Current output 0(4)...20 mA

### Use in coupled IT systems

Only one A-ISOMETER® may be active when several IT systems are interconnected. Isometer disconnecting relays and the control inputs F1/F2 integrated in version IRDH375B guarantee that this requirement will always be met and make them suitable for coupled systems too.

### Measuring principle

**AMP<sup>Plus</sup>** The IRDH375(B) series uses the patented **AMP<sup>Plus</sup>** measuring principle (refer to chapter Annex – "Technical aspects..."). This measuring principle allows concise monitoring of modern power supply systems, also in case of extensive, directly connected DC components and high system leakage capacitances.

Operating elements

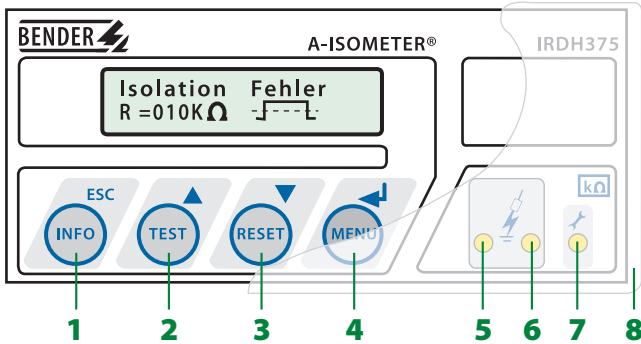

- 1 - INFO key: to query standard information  
ESC key: back to the menu function
- 2 - TEST button: to call up the self test.  
Arrow up key: Parameter change, scroll.
- 3 - RESET button: to delete alarm and fault messages  
Arrow down key: Parameter change, scroll.
- 4 - MENU key: to activate the MENU system  
Enter key: To confirm parameter change.
- 5 - Alarm LED 1, yellow, lights when the value falls below the set response value  $R_{ALARM1}$
- 6 - Alarm LED 2, yellow, when the value falls below the set response value  $R_{ALARM2}$
- 7 - Alarm LED, yellow, lights in case of fault in the connecting leads to the system or to earth, or in case of system fault
- 8 - Transparent front plate cover (accessory)

Response times

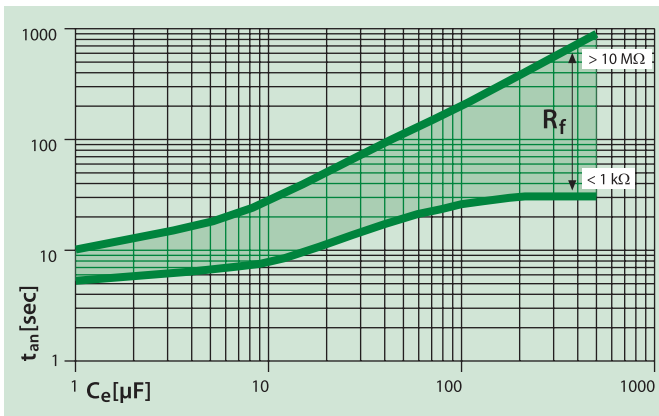

Wiring diagram

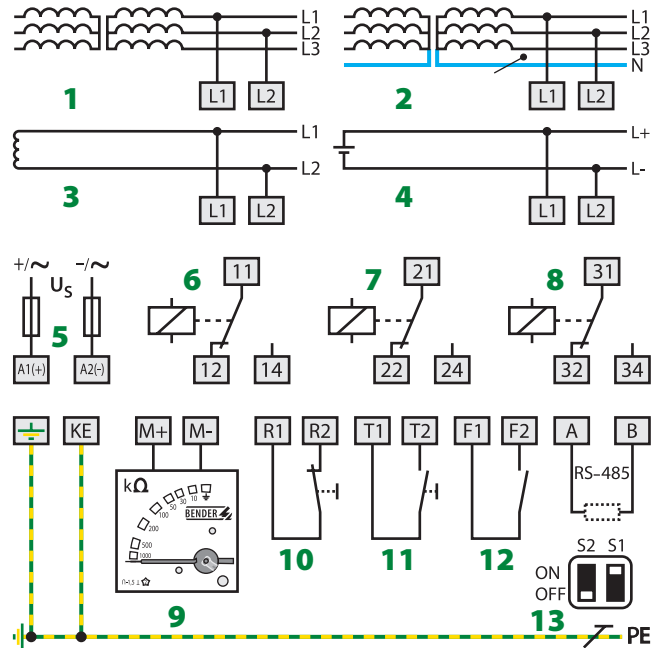

- 1 - 3AC system
- 2 - 3NAC system
- 3 - AC system
- 4 - DC system
- 5 - Supply voltage  $U_s$  see ordering information, 6 A fuse
- 6 - Alarm relay  $R_{ALARM1}$
- 7 - Alarm relay  $R_{ALARM2}$
- 8 - Alarm relay system fault
- 9 - External  $k\Omega$  indication 0...400  $\mu A$  or current output 0(4)...20 mA (option)
- 10 - External reset button (N/C contact or wire jumper) when the terminals R1/R2 are open, the fault message will not be stored.
- 11 - External test button, if required
- 12 - Measurement suppression, when the contact is closed, no measurement takes place, system disconnection (option).
- 13 - DIP switch, S1 "ON"- RS-485 terminated (120  $\Omega$  on), S2 - unassigned

Wiring diagram – back of the device

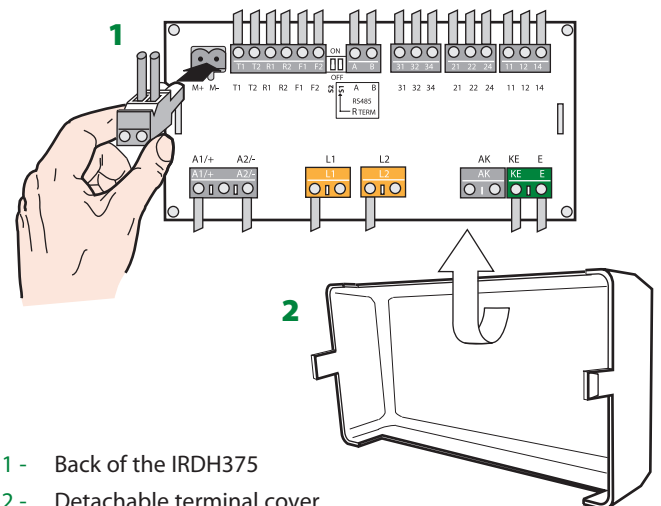

- 1 - Back of the IRDH375
- 2 - Detachable terminal cover

1.5

**Wiring diagrams –  
IRDH375 connected to different types of coupling devices**

**A-ISOMETER® IRDH375 with coupling device AGH150W-4**

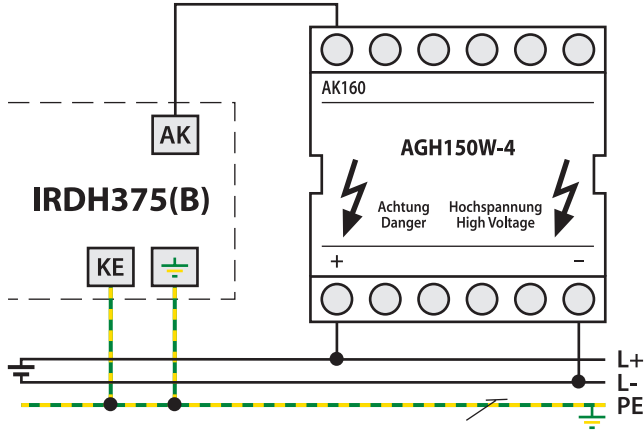

$U_n$  DC 0...1760 V

**A-ISOMETER® IRDH375 with coupling device AGH204S-4**

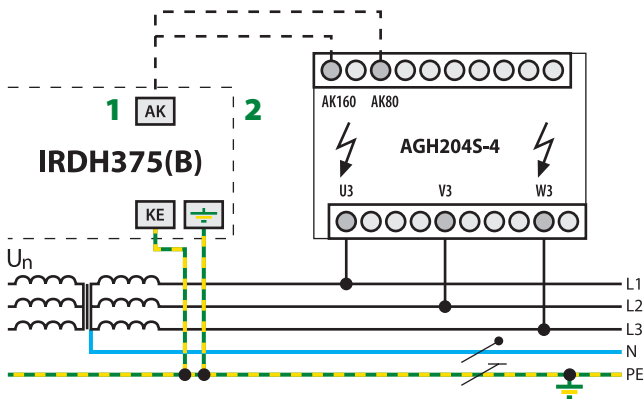

- 1 - without rectifier  $U_n = 3AC\ 0...1650\ V$
- 2 - with rectifier  $U_n = 3AC\ 0...1300\ V$   
(peak voltage downstream of the rectifier or intermediate voltage max. DC 1840 V)

**A-ISOMETER® IRDH375 with coupling device AGH520S**

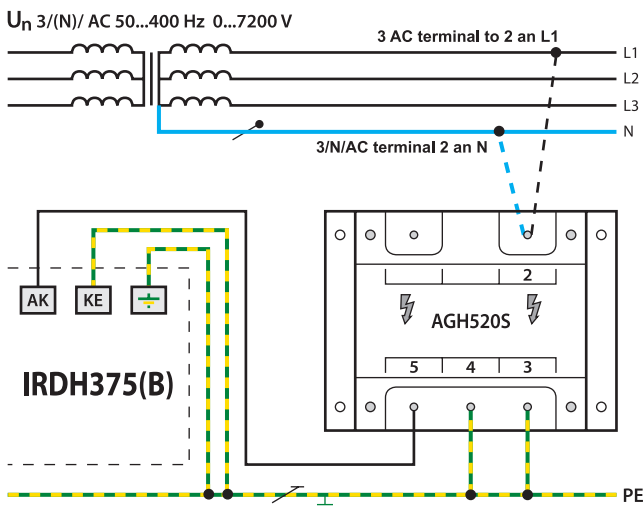

**Ordering information**

Type	Nominal voltage $U_n$	Supply-voltage $U_s$	Art. No.
IRDH375-435	AC 0...793 V/ DC 0...650 V*	AC 88...264 V/ DC 77...286 V*	B 9106 5000
IRDH375-427	AC 0...793 V/ DC 0...650 V*	DC 19.2...72 V*	B 9106 5002
IRDH375B-435	AC 0...793 V/ DC 0...650 V*	AC 88...264 V/ DC 77...286 V*	B 9106 5004
IRDH375B-427	AC 0...793 V/ DC 0...650 V*	DC 19.2...72 V*	B 9106 5006

\* absolute values

**Accessories**

**External kΩ measuring instruments (400 μA)**

Type	SKMP *2)	Art. No.
7204-1421	120 kΩ	B 986 763
9604-1421	120 kΩ	B 986 764

\*2) SKMP = scale centre point

**External kΩ measuring instrument 20 mA**

Type	Art. No.
9620-1421	B 986 841

**Transparent front plate cover IP65**

Type	Art. No.
144 x 72	B 9806 0005

**Coupling devices**

Type	Nominal system voltage $U_n$	Art. No.
AGH150W-4	DC 0...1760 V	B 9801 8006
AGH204S-4	AC 0...1300 V/0...1650 V	B 914 013
AGH520S	AC 0...7200 V	B 913 033

**Technical data A-ISOMETER® IRDH375**
**Insulation coordination acc. to IEC 60664-1**

Rated insulation voltage	AC 800 V
Rated impulse voltage/pollution degree	8 kV/3

**Voltage ranges**

Nominal system voltage $U_n$	AC, 3(N)AC 0...793 V/DC 0...650 V
Rated frequency $f_n$	DC, 0.2...460 Hz
Supply voltage $U_s$	see ordering information
Frequency range $U_s$	20...460 Hz
Power consumption	≥ 14 VA

**Response values**

Response value $R_{an1}$ (Alarm 1)	1 kΩ...10 MΩ
Response value $R_{an2}$ (Alarm 2)	1 kΩ...10 MΩ
Absolute error (1 kΩ...10 kΩ)	+ 2 kΩ
Relative percentage error (10 kΩ...10 MΩ)	0%...+ 20%
Measuring time	see characteristic curves
Hysteresis (1 kΩ...10 kΩ)/(10 kΩ...10 MΩ)	+ 2 kΩ/25%

**Measuring circuit**

Measuring voltage $U_m$	≤ 40 V
Measuring current $I_m$ (at $R_F = 0 \Omega$ )	≤ 220 μA
Internal DC resistance $R_i$	≥ 180 kΩ
Impedance $Z_i$ at 50 Hz	≥ 180 kΩ
Permissible extraneous DC voltage $U_{fg}$	≤ 1200
Permissible system leakage capacitance	≤ 500 μF
Factory set system leakage capacitance $C_e$	150 μF

**Displays**

Display (illuminated)	two-line display
Characters (number of characters, height)	2 x 16 characters/5 mm
Display range, measuring value	1 kΩ...10 MΩ
Absolute error 1 kΩ...10 kΩ	± 1 kΩ
Percentage operating error 10 kΩ...10 MΩ	± 10%

**Outputs**

Test/reset button	internal/external
Current output measuring instrument	SKMP 120 kΩ
Load	≥ 400 μA (12.5 kΩ)
Load B' version	≥ 20 mA (500 Ω)

**Serial interfaces**

IRDH375	RS-485/ASCII
IRDH375B	RS-485/BMS
Max. cable length	1200 m
Recommended cable (shielded, shield on one side connected to PE)	J-Y(ST)Y 2 x 0.6
Terminating resistor	120 Ω (0.5 W)

**Switching elements**

Number of switching elements	3 x 1 changeover contact
Operating principle	N/O operation / N/C operation
Factory setting	N/O operation
Electrical service life, number of cycles	12000
Contact class	IIB in accordance with DIN IEC 60255-0-20
Rated contact voltage	AC 250 V/DC 300 V
Making capacity	AC/DC 5 A
Breaking capacity	2 A, AC 230 V, cos phi = 0,4 0.2 A, DC 220 V, L/R = 0.04 s
Minimum contact current at DC 24 V	2 mA (50 mW)

**General data**

Shock resistance IEC 60068-2-27 (during operation)	15 g/11 ms
Bumping IEC 60068-2-29 (during transport)	40 g/6 ms
Vibration resistance IEC 60068-2-6 (during operation)	1 g/10...150 Hz
Vibration resistance IEC 60068-2-6 (during transport)	2 g/10...150 Hz
Ambient temperature (during operation)	-10 °C...+55 °C
Ambient temperature (during storage)	-40 °C...+70 °C
Climatic class acc. to DIN IEC 60721-3-3	3K5
Operating mode	continuous operation
Mounting	any position
Connection	plug-in terminals
Connection properties rigid/flexible	0.2...4 mm <sup>2</sup> /0.2...2.5 mm <sup>2</sup>
Degree of protection, internal components (DIN EN 60529)	IP 30
Degree of protection, terminals (DIN EN 60529)	IP 20
Flammability class	UL94V-1
Product standards	DIN EN 61557-8: 1998-05 EN 61557-8: 1997-03, IEC 61557-8: 1997-02 ASTM F1669M-96, ASTM F1207M-96
Operating manual	TGH1352
Weight approx.	650 g

**Dimension diagram X300**

Dimensions are given in mm

