

A-ISOMETER® IR485P, IR486P

Insulation monitoring device for IT AC and DC systems
for integration into converter systems

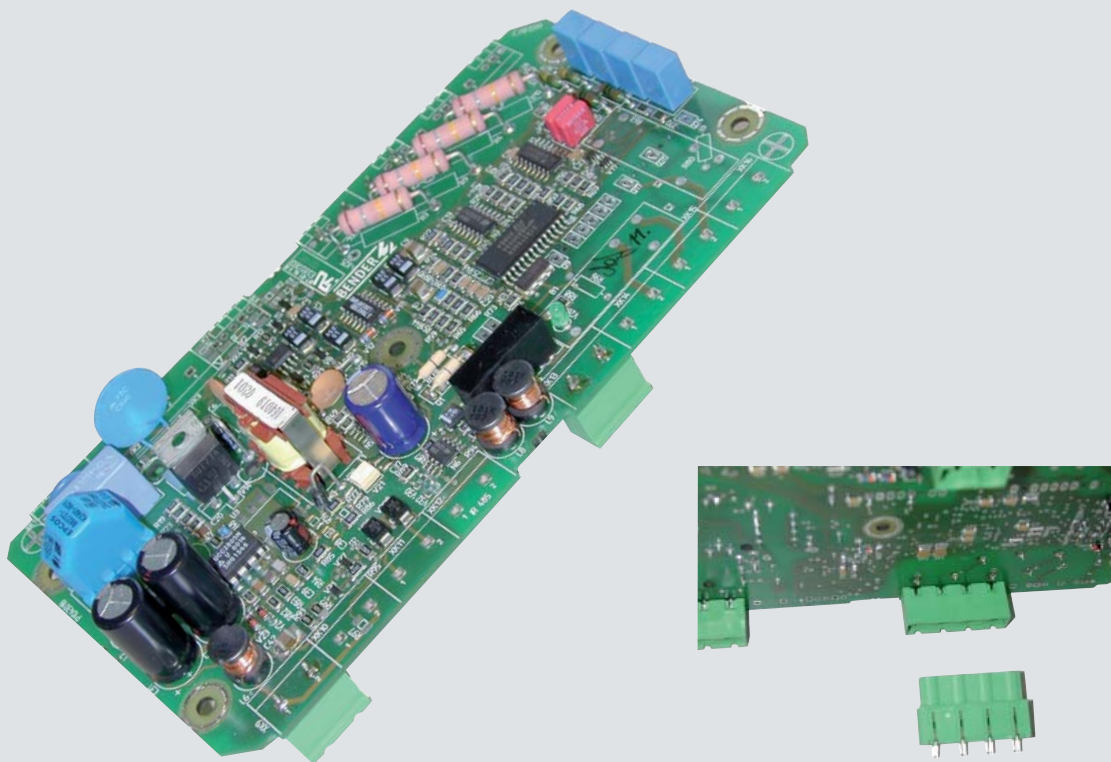

A-ISOMETER®

IR485P, IR486P

Insulation monitoring device for IT AC and DC systems
for integration into converter systems



IR486

Device features

IR485

- for IT AC systems up to AC 460 V,
for IT DC systems up to DC 1000 V
- Connection monitoring
- Power On LED
- Voltage output 0...10 V
- high mechanical stress resistance
- extended ambient temperature range
- particularly suited for fuel cell-supplied
converters

IR486

- for IT AC systems up to AC 800 V,
for IT DC systems up to DC 1000 V
- Connection monitoring
- Response value 50 kOhm
- Power On LED
- Alarm relay with one normally
open changeover contact

Product description

The A-ISOMETER® IR485P and IR486P monitor the insulation resistance of unearthed AC systems up to AC 460 V or DC systems up to DC 1000 V. Insulation faults in DC circuits which are directly connected to the AC system are only monitored correctly when the rectifiers carry a load current > 5...10 mA. Hence, these devices are capable of being integrated into converter systems.

Application in modern power supply systems

- Electric vehicle technology
- UPS systems
- Charging stations

Measuring principle



The A-ISOMETER® IR485P-421 and IR486P-421 use the AMP measuring principle. This ensures safe monitoring of modern power supply systems. Refer to the Bender main catalogue, part 1, for a detailed description of the measuring principle.

Standards

The A-ISOMETER® of the IR485P and IR486P series comply with the standards: DIN EN 61557-8 (VDE0413 Teil 8):1998-05, EN 61557-8: 1997-03, IEC 61557-8: 1997-02 and ASTM F 1669 M-96.

Please read carefully all the safety instructions provided before installing the device.

Ordering details

Type	Supply voltage U_s	Nominal voltage range U_n	Art. No.
IR485P-421	DC 12...84 V	AC 50...400 Hz 0...800 V DC 0...1000 V	B 9106 8098
IR486P-421	DC 12...84 V	AC 50...400 Hz 0...800 V DC 0...1000 V	B 9106 8099

Wiring diagram

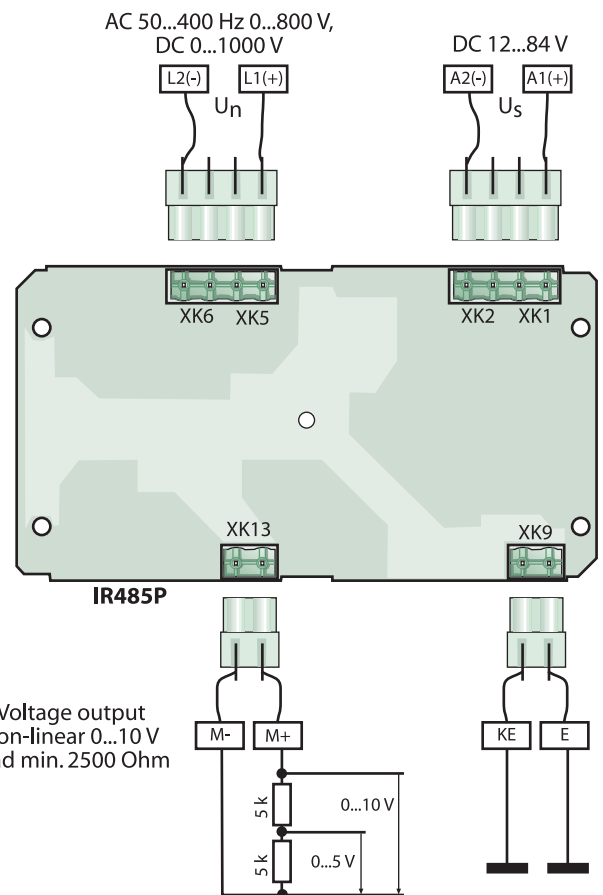
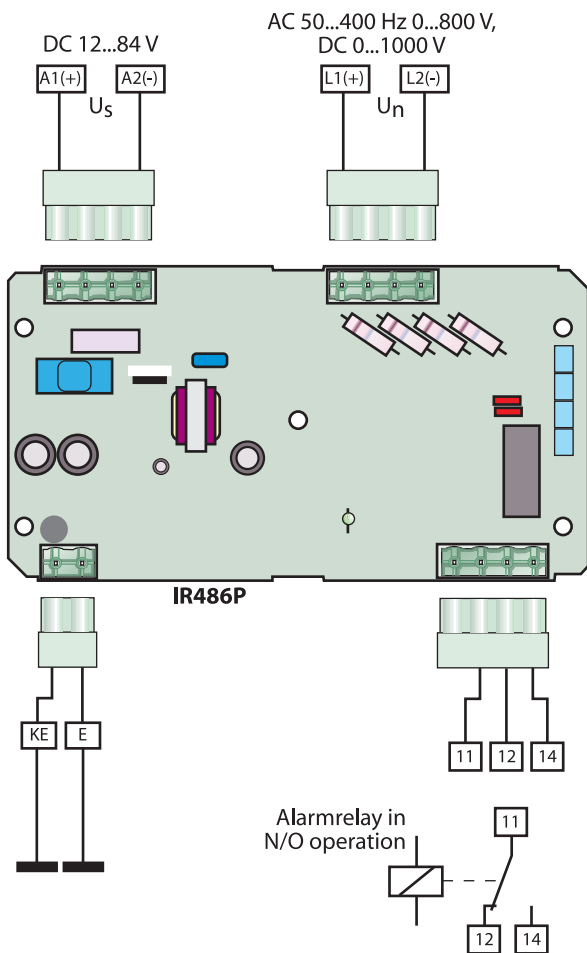
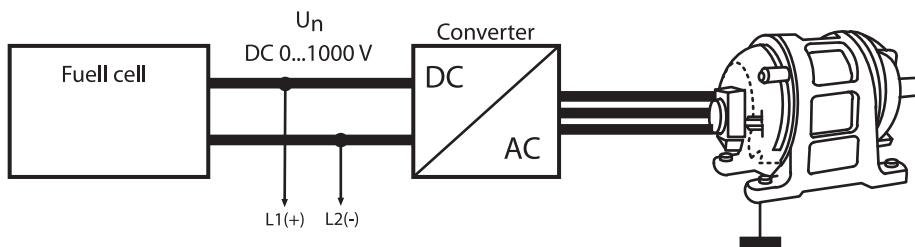

Voltage output non-linear 0...10 V load min. 2500 Ohm

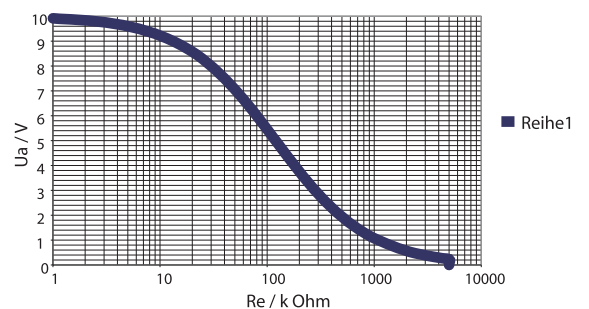

Technical data

Insulation coordination acc. to IEC 60664-1

Rated insulation voltage	AC 1000 V
Rated impulse withstand voltage/contamination level	8 kV / 2

Voltage range

Supply voltage U_s	DC 12...84 V
Nominal voltage range U_n	AC 50...400 Hz 0...800 V, DC 0...1000 V
Max. power consumption	3 VA

Response value

IR485P-...	-
IR486P-...	50 kOhm
Max. admissible system leakage capacitance	Ce 20 μ F

Measuring circuit

Measuring voltage U_m	+/- 30 V
Internal resistance R_i	200 kOhm

Outputs

IR485P-...

non-linear isolated output
with 0...10 V equivalent to 5 MOhm ... 0 Ohm

IR486P-...

Switching components	1 changeover contact
Rated contact voltage	AC 250 V / DC 300 V
Admissible number of operations	12000
Making capacity	UC 5 A

Breaking capacity

AC 230 V, cos phi = 0.4	AC 2 A
DC 220 V and L/R = 0.04s	DC 0.2 A
Arbeitsweise	N/O operation

Type tests Test of the electromagnetic compatibility (EMC)

Interferences acc. to	EN 61000-6-2
Emissions acc. to	EN 50081-2
Emissions acc. to EN 55 011/CISPR11	class A ¹⁾

Mechanical tests IR485P-...

Vibration 3 axes,	10...1500 Hz at 5 g
Shock	1/2 sine-wave amplitude at 50 g

Mechanical tests IR486P-...

Shock resistance acc. to IEC 60255-5	15 g / 11 ms
Constant shocks acc. to IEC 6068-2-29	40 g / 6 ms
Vibration resistance acc. to IEC 6068-2-6	10...150Hz / 0.15 mm - 2g

General data

Ambient temperature IR485P-... during operation	-40 °C ... +75 °C
storage temperature range	-60 °C ... +105 °C
Ambient temperature IR486P-... during operation	-25 °C ... +70 °C
storage temperature range	-40 °C ... +70 °C
Climatic class acc. to IEC 60721	3k5 except condensation and formation of ice
Operating mode	continuous operation
Mounting	any position
Connection	plug-in terminals, Phönix 7.62 mm
Schutzart nach DIN EN 60529	IP 00
Dimensions	84 x 157 x 47 mm (max. dimensions, incl. plug-in connectors)
Weight approx.	130 g

¹⁾ only for use in the industrial sector

Dimension diagram

Dimensions in mm

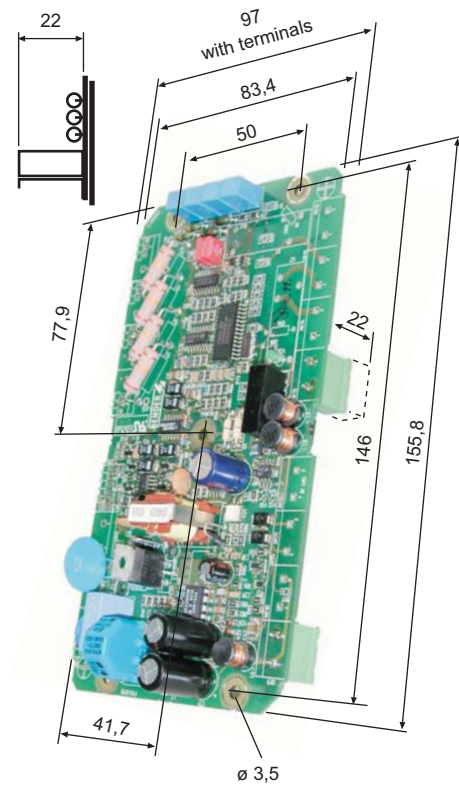

Dipl.-Ing. W. Bender GmbH & Co KG

P.O. Box 1161 • 35301 Grünberg • Germany

Londorfer Straße 65 • 35305 Grünberg • Germany

Phone: +49 6401 807-0 • Fax: +49 6401 807-259

E-Mail: info@bender-de.com • www.bender-de.com

The power in electrical safety