

Protocol converter FTC470XMB

Protocol converter to interface the BMS bus with Modbus RTU



FTC470XMB

Product description

The protocol converter FTC470XMB is designed to transmit data from the BMS bus to the Modbus RTU and vice versa. In this way, information from communication-capable BENDER products, such as EDS, RCMS or MEDICS® systems can be integrated into a Modbus RTU system. Programming and adaptations on the PROFIBUS DP side have to be carried out by the user. In mode 1, up to 10 BMS-compatible BENDER devices can be displayed with one FTC470XMB.

Application

- Transmitting all BMS data to Modbus RTU
- Displaying BENDER data on Modbus-RTU-compatible software
- Reactions on the Modbus RTU side to BMS events
- Control of BMS systems via Modbus RTU
- Connection to Modbus-RTU-compatible building services management systems
- Reactions on the BMS side to events on the Modbus RTU side

Function

The protocol converter FTC470XMB is incorporated into the Modbus RTU network as a slave and in a BMS system either as a master or a slave. The Modbus RTU master, e.g. a personal computer utilizing a Modbus RTU interface or a PLC must be programmed in a way that the protocol converter is capable of sending the respective requests and getting the replies. For appropriate programming, the user is required to have a thorough Modbus RTU knowledge. The entire command syntax is a component of the FTC470XMB manual.

Approvals



Operating elements

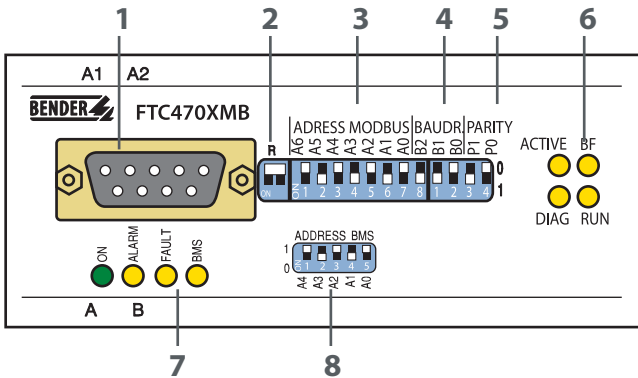

- 1 - Socket for Modbus RTU cable: 9-pin SUB-D
- 2 - Micro switch for Modbus RTU termination: "ON" = terminating resistor activated
- 3 - DIP switches for binary addressing of Modbus RTU: 1...127
- 4 - DIP switches for binary baud rate setting of Modbus RTU: 1200...57600 bit / s
- 5 - DIP switches for binary parity setting of Modbus RTU: none / even / odd
- 6 - Modbus RTU status indication
- 7 - BMS bus status indication
- 8 - DIP switches for binary BMS bus address setting: 1...30

Wiring diagram

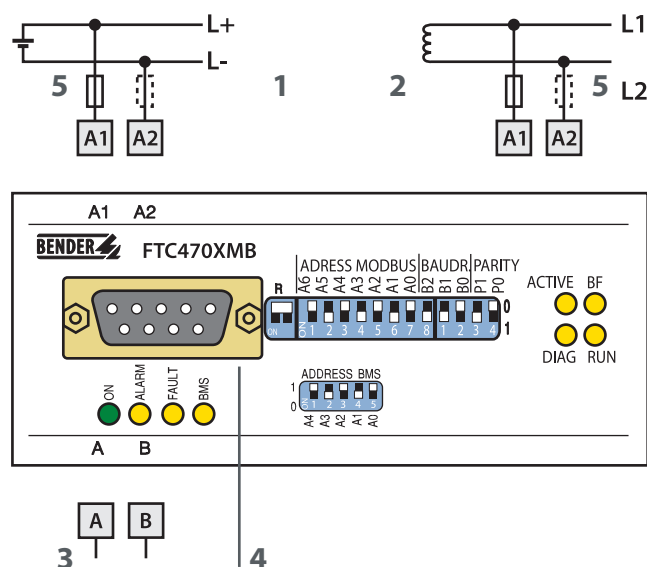

- 1 - Connection to supply voltage $U_s = DC 85...276 V$
- 2 - Connection to supply voltage $U_s = AC 85...276 V$
- 3 - BMS bus connection
- 4 - Modbus RTU 9-pin SUB-D
- 5 - U_s see ordering information, a 6 A fuse is recommended

Technical data protocol converter FTC470XMB

Insulation coordination acc. to IEC 60664-1

Rated insulation voltage	AC 250 V
Rated impulse voltage / pollution degree	4 kV / 3

Supply voltage

Supply voltage U_S	see ordering information
Frequency range of U_S	DC, 50...400 Hz
Power consumption	≤ 12 VA

Interfaces

BMS

Interface / protocol	RS-485 / BMS (internal)
Baud rate	9.6 kbit / s
Cable length	≤ 1200 m
Recommended cable (shielded, shield on one side connected to PE)	J-Y(ST)Y min. 2 x 0.6
Mode	Master / Slave
Connection terminals A / B	
Terminating resistor	120 Ω (0.25 W)
Device address, BMS bus	DIP switch 1...30
Alarm LEDs	ON / Alarm / FAULT / BMS

Modbus

Interface / protocol	RS-485 / Modbus RTU
Mode	Modbus RTU slave
Connection	9-pole Sub-D
Alarm LEDs	Active / bus error / Diag / Run
Baud rate	1.2...57.6 kBit / s
Terminating resistor	DIP switch
Address assignment Modbus RTU	DIP switch 1...127

General data

EMC immunity	acc. to EN 61000-6-2	
EMC emission	acc. to EN 61000-6-4	
Classification of climatic conditions acc. to IEC 60721	Stationary use	3K5
	Transport	2K3
	Storage	1K4
Operating temperature	- 10 °C...+ 55 °C	
Classification of mechanical conditions acc. to IEC 60721	Stationary use	3M4
	Transport	2M2
	Storage	1M3
Operating mode	continuous operation	
Mounting	any position	
Connection	screw terminals	
Connection properties		
rigid / flexible / conductor sizes	0.2...4 / 0.2...2.5 mm ² / AWG 22-12	
flexible with ferrule, without / with plastic sleeve	0.25...2 mm ²	
Stripping length	8 mm	
Tightening torque	0.5 Nm	
Degree of protection, internal components (IEC 60529)	IP30	
Degree of protection, terminals (IEC 60529)	IP20	
Type of enclosure / dimension diagram	X470	
Screw mounting	2 x M4	
DIN rail mounting acc. to	IEC 60715	
Flammability class	UL94V-0	
Operating Manual	TGH1367	
Weight	≤ 360 g	

Ordering information

Type	Supply voltage U_S	Art. No.
FTC470XMB	AC / DC 85...276 V*	B 9506 1002

* Absolute value

Dimension diagram X470

Dimensions in mm

